

Enrollment No: _____

Exam Seat No: _____

C.U. SHAH UNIVERSITY

Winter Examination-2022

Subject Name: Basics of Civil & Structural Engineering

Subject Code: 4TE02BCS1

Branch: B.Tech (All)

Semester: 2

Date: 21/09/2022

Time: 11:00 To 02:00

Marks: 70

Instructions:

- (1) Use of Programmable calculator & any other electronic instrument is prohibited.
 - (2) Instructions written on main answer book are strictly to be obeyed.
 - (3) Draw neat diagrams and figures (if necessary) at right places.
 - (4) Assume suitable data if needed.
-

Q-1 Attempt the following Questions

(14)

1)The main principal of surveying is to work from

- (A) Part to the whole (B) Whole to the part
(C) Higher to lower level (D) Lower level to higher level

2)The line joining points of equal elevation (RL) is known as a

- (A) Horizontal line (B) Gradient line (C) Contour line (D) Level line

3)If the resultant of two forces has the same magnitude as either of the force, then the angle between the two forces is

- (A) 30° (B) 45° (C) 60° (D) 120°

4)In the WCB system, a line is said to be free from local attraction if the difference between the FB and BB is

- (A) 0° (B) 90° (C) 180° (D) 360°

5) Tungsten steel is normally used in the manufacture of

- (a) drilling machines (b) heavy earth equipment
(c) heavy mining equipment (d) delicate instruments

6)The longest chain line passing through the center of the area is known as

- (a) Base line (b) Check line (c) Tie line (d) None of the above

7) The point in the body where the entire weight is assumed to be concentrated is known as (a) M.I (b) C.M (c) C.G (d) C.R

8) What is the principle of chaining?

9) State parallelogram law of force



- 10) Define : Leveling.
- 11) Expand GIS and GPS.
- 12) Write various types of stones.
- 13) What is meant by ranging?
- 14) What is radius of gyration?

Attempt any four from Q-2 to Q-8:

Q-2)

- 1) Explain the various types of cement used for construction. (4)
- 2) A 20m chain was found to be 8cm too long at the end of days work after measuring 4000m. If the chain was correct before the commencement of work, find the correct length of the line. (6)
- 3) Differentiate between prismatic compass and surveyors compass (4)

Q-3)

- 1) Explain the various methods of leveling with neat sketches. (7)
- 2) The following observations were taken with dumpy level and four-meter levelling staff. The instrument was shifted after the fourth and seventh readings. The first reading was taken on a bench mark whose RL is 15.575m. Prepare a page of level book and calculate RLs of all the points. The observations were taken at a every 30m interval. Also find out the gradient between first and last point. Also draw the profile of ground. Use H.I method. Observations are: 0.565; 1.250; 1.675; 3.695; 0.125; 2.345; 3.245; 0.500; 1.785; 2.535. (7)

Q-4)

- 1) Determine moments of inertia of a section shown in fig. 01 about horizontal centroidal axis. (7)

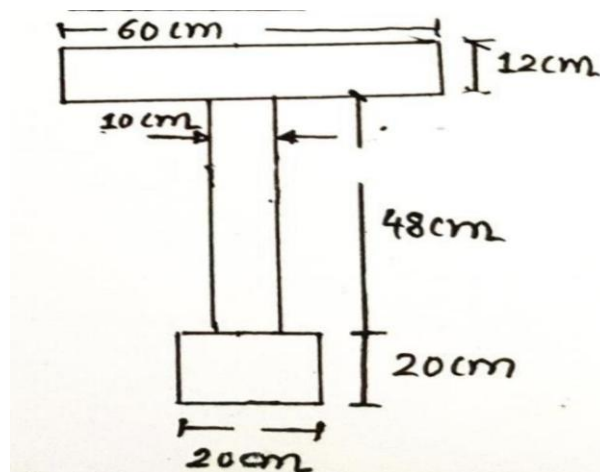

Fig. 01.

2) Write assumptions made in the analysis of plane truss. Distinguish between perfect, unstable and redundant trusses. Illustrate with sketches. (7)

Q-5)

Determine the forces in all the members of the truss shown in Figure.2. All inclined members are at 60° to horizontal and length of each member is 2 m. (14)

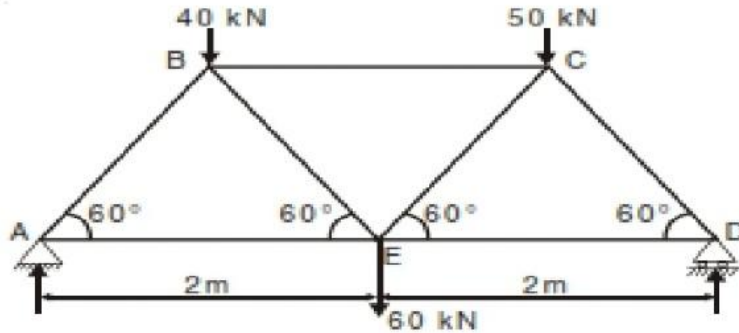

Fig.02

Q-6)

1) In closed traverse the following bearings were observed with a compass. Calculate the interior angles. (7)

Line	Fore bearing
AB	$65^\circ 00'$
BC	$125^\circ 30'$
CD	$200^\circ 00'$
DE	$265^\circ 15'$
EA	$330^\circ 00'$

2) Explain different type of force system with suitable example and sketch (7)

Q-7)

- 1) What is local attraction in compass? How you can predict the same? (7)
- 2) Write short notes on the importance of sand and aggregate in construction (7)

Q-8)

- 1) Explain Lami's theorem. (7)
- 2) What is effect of civil engineering branch on growth of mankind. (7)

